

Electromagnetic Door Holders Datasheet

Door Holders

Product Overview

Morley-IAS range of door holders provide attractive aesthetics and high performance for buildings requiring an automatic door release function in the event of a fire emergency.

Each door holder is fitted with a spring loaded release pin mounted centrally within the electromagnet. On power off, the release pin then pushes the door away from the electromagnet. This overcomes any residual magnetism ensuring correct operation.

The D.C. unit is fitted with a suppression diode and protection against reverse polarity such that it may be operated from a reverse polarity monitored circuit.

All the electromagnets are designed to comply with the latest requirements of EN61000-3-2, EN50081-1, EN60950 and EN1155.

The low profile, flame retardant ABS housing results in an attractive and robust design and contains a push button for quick, easy release of the door.



Key Features

- Low profile design
- 200N holding force
- Easy cable entry & exit
- A.C. or D.C. options
- Push button release/test
- Floor mounting bracket available
- Anti-residual magnetism feature
- D.C. version polarised and suppressed feature

MORLEY



IAS

FIRE SYSTEMS

by Honeywell

Door Holders

Door holders are designed to hold a fire door in the open position until a fire is detected in the area and the fire alarm control panel signals to release the doors. The doors then close aided by the self closing mechanism fitted to the door in order to compartmentalise the building, reducing the spread of smoke and fire.

All the electromagnets are designed to comply with the latest requirements of EN61000-3-2, EN50081-1, EN60950 and EN1155 (CPD Approved)



Specification

FLOOR MOUNTED 24V DC DOOR HOLDER - 04390-41

Mechanical Specification

Approx Weight	700g
Finish	White painted housing, zinc plated magnet
Holding Force	200N

Electrical Specification

Voltage	24V dc
Current Consumption	45mA

Environmental Specifications

Ambient Temperature	0°C to +35°C
---------------------	--------------

WALL MOUNTED 24V DC DOOR HOLDER - 04390-31

Mechanical Specification

Approx Weight	360g
Finish	White Fire Resistant ABS
Holding Force	200N

Electrical Specification

Voltage	24V dc
Current Consumption	45mA

Environmental Specifications

Ambient Temperature	0°C to +35°C
---------------------	--------------

Approvals

EN1155 :1997 (CPD Approved)

WALL MOUNTED 230V AC DOOR HOLDER - 04390-55

Mechanical Specification

Approx Weight	360g
Finish	White Fire Resistant ABS
Holding Force	200N

Electrical Specification

Voltage	230V ac
Current Consumption	12mA

Environmental Specifications

Ambient Temperature	0°C to +40°C
---------------------	--------------

Approvals

EN1155 :1997 (CPD Approved)

Dimensions

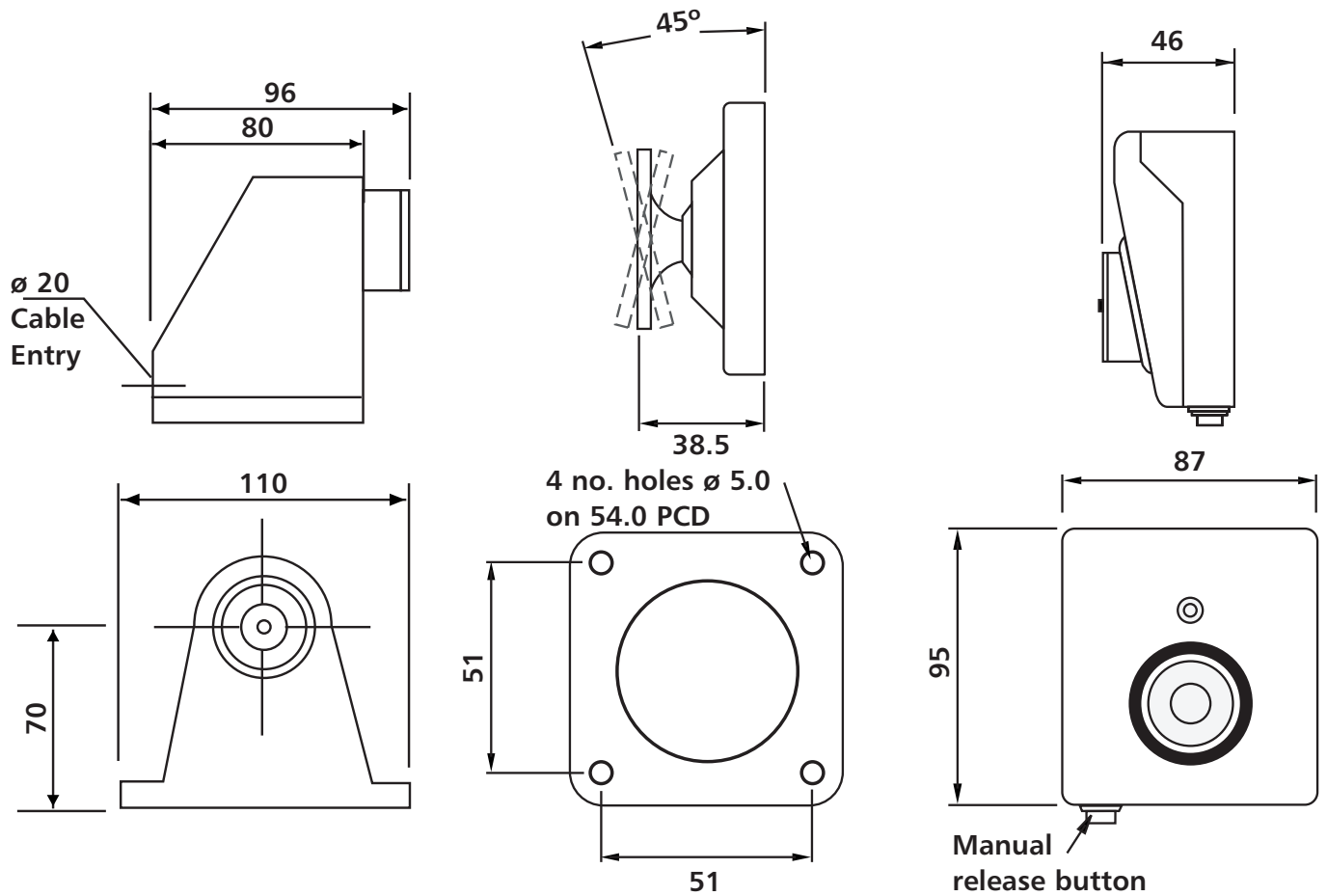

DESCRIPTION

Magnet Door Holder 24V DC 22mA

Magnet Door Holder floor mounted 24V DC 45mA

Magnet Door Holder 240V AC 17.5mA

Door Holder Floor Plate; fixing door holder at right angle to floor

Door Plate Assembly (Spare), Door Keeper Plate in two pieces

Door Hold Transformer-Rectifier 24V 2A

Door Hold Transformer-Rectifier 24V 4A

ORDER CODES

04390-31

04390-41

04390-55

04390-92

04390-99

HLS-PSU-TR20

HLS-PSU-TR40



MORLEY  **IAS**
FIRE SYSTEMS
by Honeywell

Charles Avenue
Burgess Hill
West Sussex
RH15 9UF UK

T +44 (0) 1444 235 556
F +44 (0) 1273 376 694
E sales@morleyias.co.uk
www.morley-ias.co.uk